

MAT15MN

ENERGY ADVANTAGE™
MAYTAG® COMMERCIAL
TOP-LOAD WASHER



LEGENDARY MAYTAG DEPENDABILITY

Maximizing your equipment investment for over half a century.



FOR YOUR OPERATION:

- The Most Efficient, Best Cleaning Top-Load Washer From Maytag
- Extra-Large Lid And Tub Opening
- Dial-A-Fabric™ Cycle Selection
- Cycle Stage Indicator Lights
- Front Access For Easier Self-Service
- Extra Large Tub Capacity

BUILT-TO-LAST™ FEATURES:

- Premium Porcelain-Enamel Top
- Beltless Design
- Dependable Direct Drive Transmission
- Self Cleaning Pump
- Reliable Electro-Mechanical Controls
- Best Warranty In The Business

**REDUCES
WATER USAGE
BY 20%***

* Compared to Maytag® top-load washers manufactured before 2005.

LAUNDRY SOLUTIONS
YOU CAN *DEPEND* ON.

CLP796



www.maytagcommerciallaundry.com

OUR COMMITMENT TO DEPENDABLE QUALITY

At Maytag, we believe durable goods should remain just that. That's why every Maytag® product is constructed of the highest-quality materials and with the utmost in precision craftsmanship. It's also why we stand behind our equipment with solid service and support from our professional Maytag laundry suppliers. Simply put, when you choose Maytag® products, you ensure your peace of mind.



MAT15MN

MAYTAG® COMMERCIAL ENERGY ADVANTAGE™ TOP LOAD WASHER

Maytag® Energy Advantage™ Top-Load Washer MECHANICAL NON-COIN

WASHER SPECIFICATIONS	
MODEL	MAT15MN
MOTOR	
Single-phase, reversible, thermoprotected, high torque	•
HP (kw)	½ (.37)
APPROXIMATE WATER USAGE — gallons (liters)	
Average hot water usage per cycle	4.1 (15.5)*
Average total water usage per cycle	30 (113.5)*
ELECTRICAL RATING	
Domestic model — voltage	120V/60 Hz
Export model — voltage	220-240V/50Hz
BREAKER/FUSE REQUIREMENT	
Domestic model — amps	15
Export model — amps	10
CYLINDER	
Volume — cu. ft. (liters)	3.2 (90.6)
Diameter — in. (mm)	20.3 (526)
Depth — in. (mm)	17.4 (442)
LID OPENING	
In. (mm)	18 (457)
EXTRACT SPEED	
Maximum rpm	640
Maximum g-force	120
OPERATING PRESSURE	
Psi (bar)	20-100 (1-8)
INLET HOSE LENGTH	
Ft. (m)	4.5 (1.37)
DRAIN HOSE LENGTH	
Ft. (m)	4.4 (1.34)
APPROXIMATE WEIGHT	
Crated — lbs. (kg)	179 (81.2)
Uncrated — lbs. (kg)	165 (74.8)

* Average based on J1 testing with factory preset cycles. See specific instructions for proper installation. Because of continuous product improvement, Maytag reserves the right to change specifications without notice.

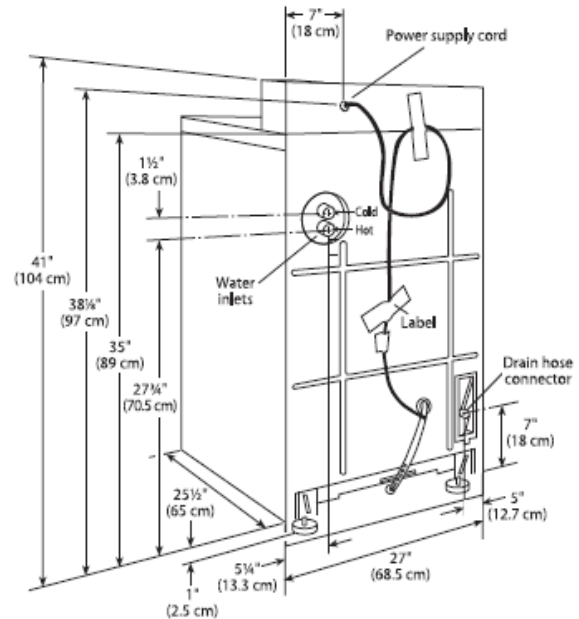

NEW YORK CITY
N.Y.C.



BEAB
Approved

Texan
Owned
Texas
Corporation



Distributor

Best Wash Inc.

15012 Eddie Drive
Humble, Texas 77396
281-441-2465
800-456-2378



5 YEARS ON ALL PARTS

For a period from the date of original purchase through the time listed above, the designated parts that fail in normal commercial use will be repaired or replaced free of charge for the part itself, with the owner paying all other costs, including labor, transportation and customs duty. Chemical damage is excluded from all warranty coverage. See complete warranty for details.